

TECHNICAL MANUAL

**OPERATOR'S, UNIT AND
DIRECT SUPPORT MAINTENANCE MANUAL
(INCLUDING REPAIR PARTS AND SPECIAL TOOLS LIST)
FOR**

**KOEHLER CLOUD AND POUR POINT
CHAMBER**

MODEL K46000

This technical manual is an authentication of the manufacturer's commercial literature and does not conform with the format and the content requirements normally associated with Army technical manuals. This technical manual does, however, contain all essential information required to operate and maintain the equipment.

Approved for public release; distribution is unlimited.

**HEADQUARTERS, DEPARTMENT OF THE ARMY
28 SEPTEMBER 1990**

This technical manual is an authentication of the manufacturer's commercial literature and does not conform with the format and the content requirements normally associated with Army technical manuals. This technical manual does, however, contain all essential information required to operate and maintain the equipment.

Approved for public release; distribution is unlimited.

SUPPLEMENTARY INTRODUCTORY MATERIAL

1-1. Maintenance Forms and Records.

Department of the Army forms and procedures used for equipment maintenance will be those described by DA Pam 738-750, The Army Maintenance Management System.

1-2. Reporting Errors and Recommending Improvements.

You can help improve this manual. If you find any mistakes or if you know of a way to improve the procedures, please let us know. Mail your letters, DA Form 2028 (Recommended Changes to Publications and Blank Forms), or DA Form 2028-2 located in the back of this manual, directly to: Commander, U.S. Army Troop Support Command, ATTN: AMSTR-MCTS, 4300 Goodfellow Blvd., St. Louis, MO 63120-1798. A reply will be furnished to you.

1-3. Destruction of Army Material to Prevent Enemy Use.

Refer to TM 750-244-3 for instructions covering the destruction of Army Material to prevent enemy use.

1-4. Administrative Storage of Equipment.

a. Placement of equipment in administrative storage should be for short periods of time when a shortage of maintenance effort exists. Items should be in mission readiness within 24 hours or within the time factors as determined by the directing authority. During the storage period appropriate maintenance records will be kept.

b. Before placing equipment in administrative storage, current preventive maintenance checks and services should be completed. Shortcomings and deficiencies should be corrected, and all modification work orders (MWO's) should be applied.

c. Storage site selection. Inside storage is preferred for items selected for administrative storage. If inside storage is not available, trucks, vans, conex containers and other containers may be used.



**K46000
CLOUD AND POUR POINT CHAMBER
ASTM D97
POUR POINT OF PETROLEUM OILS**

SAFETY AND HAZARD WARNING

THIS EQUIPMENT MAY INVOLVE HAZARDOUS MATERIAL AND OPERATIONS. THIS MANUAL DOES NOT PURPORT TO ADDRESS ALL OF THE SAFETY PROBLEMS ASSOCIATED WITH THE USE OF THE EQUIPMENT. IT IS THE RESPONSIBILITY OF WHOEVER USES THIS EQUIPMENT TO CONSULT AND ESTABLISH APPROPRIATE SAFETY AND HEALTH PRACTICES, AND DETERMINE THE APPLICABILITY OF REGULATORY LIMITATIONS PRIOR TO USE.

**KOEHLER
CLOUD AND POUR POINT CHAMBER
K46000
ASTM D97**

TABLE OF CONTENTS

SECTION:

- (A) ASTM METHOD D97
- (B) ASSEMBLY DRAWING
- (C) SPARE PARTS LIST

Designation: D97 - 66 (Reapproved 1971)

Designation: 15/67

American National Standard Z11 5-1966
American National Standards Institute
Method 201-Federal Test Method
Standard No. 791b
Deutsche Norm Din 51 597
British Standard 4452

Standard Method of Test for
POUR POINT¹

This Standard is issued under the fixed designation D 97: the number immediately following the designation indicates the year of original adoption or, in the case of revision, the year of last revision. A number in parentheses indicates the year of last reapproval. This is also a standard of the Institute of Petroleum issued under the fixed designation IP 15. The final number indicates the year of last revision.

This method was adopted as a joint ASTM-IP standard in 1965.

1. Scope²

1.1 The test for pour point is intended for use on any petroleum oil³. A procedure suitable for black oils, cylinder stock, and nondistillate fuel oil is described in 5.9.

NOTE 1

The values stated in U.S. customary units are to be regarded as the standard.

2. Summary of Method

2.1 After preliminary heating, the sample is cooled at a specified rate and examined at intervals of 5 F (or 3 C) for flow characteristics. The lowest temperature at which movement of the oil is observed is recorded as the pour point.

3. Definition

3.1 Pour point - the lowest temperature, expressed in a multiple of 5 F (or 3 C) at which the oil is observed to flow when cooled and examined under prescribed conditions.

¹ This method is under the jurisdiction of ASTM Committee D-2 on Petroleum Products and Lubricants. Current edition effective Sept 20, 1966. Originally issued in 1921. In 1927, revised and replaced former D47. Replaces D97-57. In the IP, this method is under the jurisdiction of the Standardization Committee.

² The cloud point procedure formerly part of this method now appears as ASTM Method D 2500. Test for Cloud Point of Petroleum Oils, which appears in the Annual Book of ASTM Standards, Part 17. Statements defining this test and its significance when applied to electrical insulating oils of mineral origin will be found in ASTM Methods D1 17, Testing Electrical Insulating Oils, which appear in the Annual Book of ASTM Standards, Part 29. The low temperature flow properties of a waxy fuel oil depend on handling and storage conditions. Thus, they may not be truly indicated by pour point. Additional data on low-temperature flow properties are given in ASTM Method D 1659. Test for Maximum Fluidity Temperature of Residual Fuel Oil, which appears in the Annual Book of ASTM Standards, Part 17

³ *Annual Book of ASTM Standards*, Part 18.

4. Apparatus (Fig. 1)

4.1 *Test Jar* - A cylindrical test jar of clear glass, flat bottom, 30 to 33.5 mm in inside diameter, and 115 to 125 mm in height. To indicate sample height the jar should be marked with a line 54 ± 3 mm ($2 \frac{1}{8} \pm \frac{1}{8}$ in.) above the inside bottom.

4.2 *Thermometers* - Thermometers, having ranges as shown below and conforming to the requirements as prescribed in ASTM Specification E 1 for ASTM Thermometers (see Note 4) or in the Specifications for IP Standard Thermometers:

Thermometer	Temperature Range	Thermometer Number	
		ASTM	IP
Cloud and Pour	-38 to + 50 C	5C	IC
Low Cloud and Pour	-36 to +120 F	5F	IF
	-80 to 20 C	6C	2C
	-112 to +70 F	6F	2F

4.3 *Cork* - A cork to fit the test jar. bored centrally to take the test thermometer.

4.4 *Jacket* - A watertight, cylindrical jacket of glass or metal, flat bottom, about 115 mm in depth. with inside diameter 9.5 to 12.5 mm greater than the outside diameter of the test jar.

4.5 *Disk* - A disk of cork or felt, 6 mm in thickness and of the same diameter as the inside of the jacket.

4.6 *Gasket*- A ring gasket about 5 mm in thickness. to fit snugly around the outside of the test jar and loosely inside the jacket. This gasket may be made of cork, felt, or other suitable material which is elastic enough to cling to the test jar and hard enough to hold its shape. The purpose of the ring gasket is to prevent the test jar from touching the jacket.

4.7 *Bath* - A cooling bath, of a type suitable for obtaining the required temperatures. The size and shape of the bath are optional but a support, suitable for holding the jacket firmly in a vertical position, is essential. For determination of pour points below 50 F (or 9 C) two or more baths are needed. The required bath temperatures may be maintained by refrigeration if available, otherwise by suitable freezing mixtures.

NOTE 2

The freezing mixtures commonly used are as follows:

	For temperatures down to
Ice and water	50 F (10 C)
Crushed ice and sodium chloride crystals	+10 F (-12 C)
Crushed ice and calcium chloride crystals	-15 F (-26 C)

Solid carbon dioxide and acetone or petroleum naphtha* -70 F (-57 C)

* This mixture may be made as follows: in a covered metal beaker chill a suitable amount of acetone or petroleum naphtha to 10 F (-12 C) or lower by means of an ice-salt mixture. Then add enough solid carbon dioxide to chilled acetone or petroleum naphtha to give the desired temperature. Solid carbon dioxide is commercially available in many areas. If necessary, it may be prepared as follows: invert a cylinder of liquid carbon dioxide and draw off carefully into a chamois skin bag the desired amount of solid carbon dioxide which, through rapid evaporation becomes solid.

5. Procedure

5.1 Pour the oil into the test jar to the level mark (Note 3). When necessary, heat the oil in a water bath until it is just sufficiently fluid to pour into the test jar.

NOTE 3

When it is known that a sample has been heated to some temperature higher than 115 F (46 C) during the preceding 24 h or when the thermal history of the sample is not known, keep the sample at room temperature for 24 h before testing it.

5.2 Close the test jar tightly by the cork carrying the high-pour thermometer (4.2) or in the case of pour points above 100 F (or 38 C), a thermometer as described in Note 4. Adjust the position of the cork and the thermometer so the cork fits tightly, the thermometer and the jar are coaxial, and the thermometer bulb is immersed so the beginning of the capillary is 3 mm (1/8 in.) below the surface of the oil (Note 5).

NOTE 4

For tests above 100 F (or 38 C) it is permissible to use any thermometer that includes the range from 90 to 220 F (32 to 104 C) An IP 3F Demulsification Thermometer or an ASTM 61 F Petrolatum Melting Point Thermometer is suggested.

NOTE 5

Since separation of the mercury or toluene thread or cloud and pour thermometers occasionally occurs, and since such separation may otherwise escape immediate detection, it is suggested that the ice points of the thermometers be checked immediately prior to the test. Any thermometer that shows an ice point differing from 32 F (0 C) by more than 2 F (1 C) should be further examined or recalibrated, or both, before use.

5.3 Subject the oil in the test jar to the following preliminary treatment:

5.3.1 Oils Having Pour Points Between 90 F (or 32 C) and -30 F (or -34 C)-Heat the oil, without stirring to 115 F (46 C) in a bath maintained at 118 F (48 C). Cool the oil to 95 F (or 36 C) in air or in a water bath at approximately 77 F (25 C). Proceed as directed in 5.4.

5.3.2 Oils Having Pour Points Above 90 F (or 32 C)-Heat the oil in a water bath, without stirring, to 115 F (46 C) or to a temperature approximately 15 F (or 8 C) above the expected pour point (see Note 4), whichever temperature is the higher. Proceed as directed in 5.4.

5.3.3 Oils Having Pour Points Below -30 F (or -34 C)-Heat the oil as directed in 5.3.1 and cool to 60 F(15.5 C) in a water bath maintained at 45 F (7 C). Remove the high cloud and pour thermometer and place the low cloud and pour thermometer in position. Proceed as directed in 5.4.

5.4 Place the disk in the bottom of the jacket. Place the ring gasket around the test jar, 25 mm (1 in.) from the bottom. The disk, gasket, and inside of the jacket shall be clean and dry. Insert the test jar in the jacket

5.5 Maintain the temperature of the cooling bath at 30 to 35 F (-1 to -2C). Support the jacket containing the test jar firmly in a vertical position in the cooling bath so that not more than 25 mm (1 in.) of the jacket projects out of the cooling medium.

5.6 After the oil has cooled enough to allow the formation of paraffin wax crystals, take great care not to disturb the mass of the oil nor permit the thermometer to shift in the oil; any disturbance of the spongy network of wax crystals will lead to low and fictitious results 5.7 Beginning at a temperature 15 F (or 8 C) above the expected pour point for oils having pour points above 100 F (38 C) or, for other oils, at a temperature 20 F (11 C) above the expected pour point, at each test thermometer reading that is a multiple of 5 F (or 3 C), remove the test jar from the jacket carefully and tilt it just enough to ascertain whether there is a movement of the oil in the test jar. The complete operation of removal and replacement shall require not more than 3 s. If the oil has not ceased to flow when its temperature has reached 50 F (or 10C), transfer the test jar to another jacket in a second bath maintained at a temperature of 0 to +5 F (-18 to -15 C). (The jacket may be left in the bath or transferred with the test jar.) If the oil has not ceased to flow when its temperature has reached 20 F (or 7 C),transfer the test jar to another jacket in a third bath maintained at a temperature of -30 to -25 F (-34 to 32 C). For the determination of very low pour points, additional baths are required. Each bath to be maintained at 30 F (17 C) below the temperature of the preceding bath. In each case, transfer the test jar when the temperature of the oil reaches a point 50 F (or 28C) above the temperature of the new bath. Never place the cold test jar directly into the cooling medium. As soon as the oil in the test jar does not flow when the jar is tilted, hold the test jar in a horizontal position for 5.0 s. as noted by a stop watch or other accurate timing device, and observe carefully. If the oil shows any movement under these conditions, replace the test jar immediately in the jacket and repeat a test for flow at the next temperature 5 F (or 3 C) lower.

5.8 Continue the test in this manner until a point is reached at which the oil in the test jar shows no movement when the test jar is held in a horizontal position for 5.0 s. Record the observed reading of the test thermometer.

5.9 For black oil, cylinder stock, and non distillate fuel oil the result obtained by the procedure described in 5.1 through 5.8 is the upper (maximum) pour point. If required, determine the lower (minimum) pour point by heating the sample, while stirring, to 220 F (104 C) pouring it into the jar, cooling it to 95 F (or 35 C) as before, and determining the pour point as described in 5.1 through 5.8.

6. Calculation and Report

6.1 Add 5 F (or 3 C) to the temperature recorded in 5.8 and report the result as the Pour Point, ASTM D 97-IP 15. For black oil, etc., report the result as Upper Pour Point, ASTM D 97-IP 15 or Lower Pour Point. ASTM D 97-IP 15, as required.

7. Precision

7.1 Repeatability - Duplicate results by the same operator should be considered suspect if they differ by more than 5 F (or 3 C).

7.2 Reproducibility - The results submitted by each of two laboratories should be considered suspect only if the two results differ by more than 10 F (or 6 C).

7.3 For oils tested by the procedure described in 5.9. reproducibility of this order cannot be expected, as these oils show anomalous pour points depending on their thermal history. ⁴

⁴ It is a recognized property of these oils that the temperature to which they have been subjected before testing influences their pour points. Although the lower pour points as determined by the special procedure will show approximately the reproducibility given, the upper pour points will show greater variations depending on the previous thermal history of the oils. Further information on this subject is contained in *Proceedings, ASTEA, Am Soc. Testing Mats*, Vol. 31, Part 1, 1931, pp 468-470, and Vol. 32, Part 1, 1932, pp. 402-405.

K46000

SPARE PARTS LIST

Part No.	Description	Quantity
K460-0-2	Copper Pot Assembly	1 each
K460-0-3	Outer Shell	1 each
K460-0-5	Bottom Plate	1 each
K460-0-6	Cover	1 each
K460-0-7B	Copper Cups	4 each
K460-0-8	Thermometer Holder	4 each
K299-0-32	Clips	12 each
K461-2	Disc (Cork) Bottom	4 each
K461-1	"O" Ring	4 each
AS568-131	"O" Ring	4 each



WARRANTY POLICY

Any product* manufactured by Koehler Instrument Co., Inc. (hereinafter referred to as the company) is sold on the following basis and none other. ALL IMPLIED WARRANTIES OF MERCHANTABILITY AND OF FITNESS FOR A PARTICULAR PURPOSE ARE HEREBY EXPRESSLY EXCLUDED.

The following warranty shall apply, and no other warranty, express or implied, shall apply.

If within one year from date of shipment the product fails because of defective material or poor workmanship, the company will repair or replace, without charge, any product that has failed provided:

- a) the product has been properly installed, operated and maintained.
- b) the company is advised in writing of the malfunction and authorizes the return of the product to the factory.
- c) All transportation charges for the return to the factory are prepaid. (Products will be returned freight collect.)
- d) A complete description of the reason for return must accompany the unit.

NOTE: A nominal handling charge for inspection will be made on units for which a claimed defect cannot be confirmed.

THE COMPANY'S SOLE LIABILITY HEREUNDER SHALL BE TO REPAIR OR REPLACE ANY PRODUCT WHICH HAS NOT COMPLIED WITH THIS WARRANTY.

In no event shall the company be liable for:

- 1) Prospective profits or special, indirect or consequential damages caused by failure of its product.
- 2) Any charges for labor or materials for work done on its products by others.

*Wherever used in this Warranty Policy the term "product" shall mean any items manufactured and/or sold by Koehler Instrument Co., Inc.

PRODUCT: K46000

**Test Name: Cloud and Pour Points of
Petroleum Oils**

Cloud and Pour Point Chamber

- Conforms to ASTM D97, D2500
and related specifications
- Four sample capacity

For cloud point and pour point determinations on petroleum oils. Immerses four copper test jackets in suitable freezing mixtures at the required depth per ASTM specifications. Sturdy steel outer shell with polyurethane enamel finish and all copper interior are corrosion resistant. Phenolic top plate and 1/2" (13 mm) cork insulation on sides aid in cold retention. Has convenient handles for emptying of cooling mixture.

SPECIFICATIONS

Conforms to the specifications of:

ASTM D97, D2500, FTM 791-201, IP 15,
219, DIN 51597, ISO 3015, 3016

Dimensions, dia. x h, in. (cm)

10½ x 12 (27 x 30)

SHIPPING INFORMATION

Net Weight: 14 lbs (6.3 kg)
Shipping Weight: 18 lbs (8.2 kg)
Dimensions: 20 x 16 x 14"
(51 x 41 x 36)

ORDERING INFORMATION

Supplied with copper jackets, cork rings and cork gaskets. Order test jars and thermometers separately.

Catalog

No. Description

K46000 Cloud and Pour Point Chamber

Accessories

332-004-001	Test Jar Clear, flat bottom jar with sample height graduation
250-00045F	ASTM 5 F Thermometer High Cloud and Pour Range: -36 to 120°F
250-000-05C	ASTM 5 C Thermometer High Cloud and Pour Range: -38 to 50°C
250-000-06F	ASTM 6F Thermometer Low Cloud and Pour Range: -112 to 70°F
250-000-06C	ASTM 6C Thermometer Low Cloud and Pour Range: -80 to 20°C
K46010 Replacement Cork Gasket	
K46020 Replacement Cork disc	

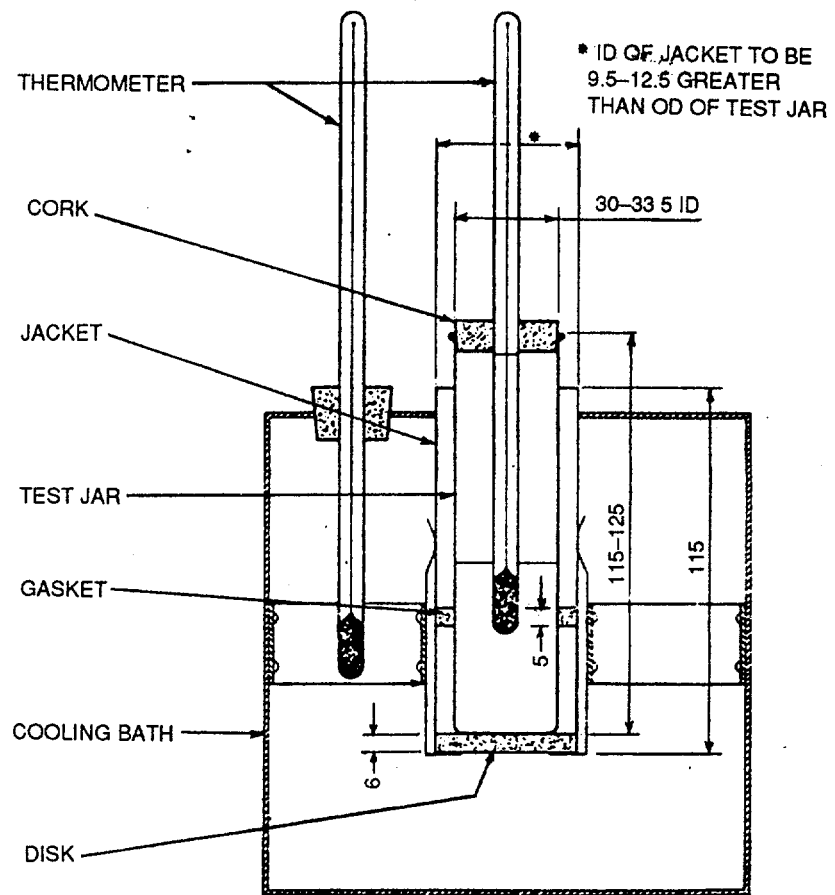

NOTE: Dimensions are in millimeters.

FIG. 1. Apparatus for Pour Test.

K460 4-UNIT CLOUD & POUR

GEN. ARRANGEMENT

1/3 SIZE

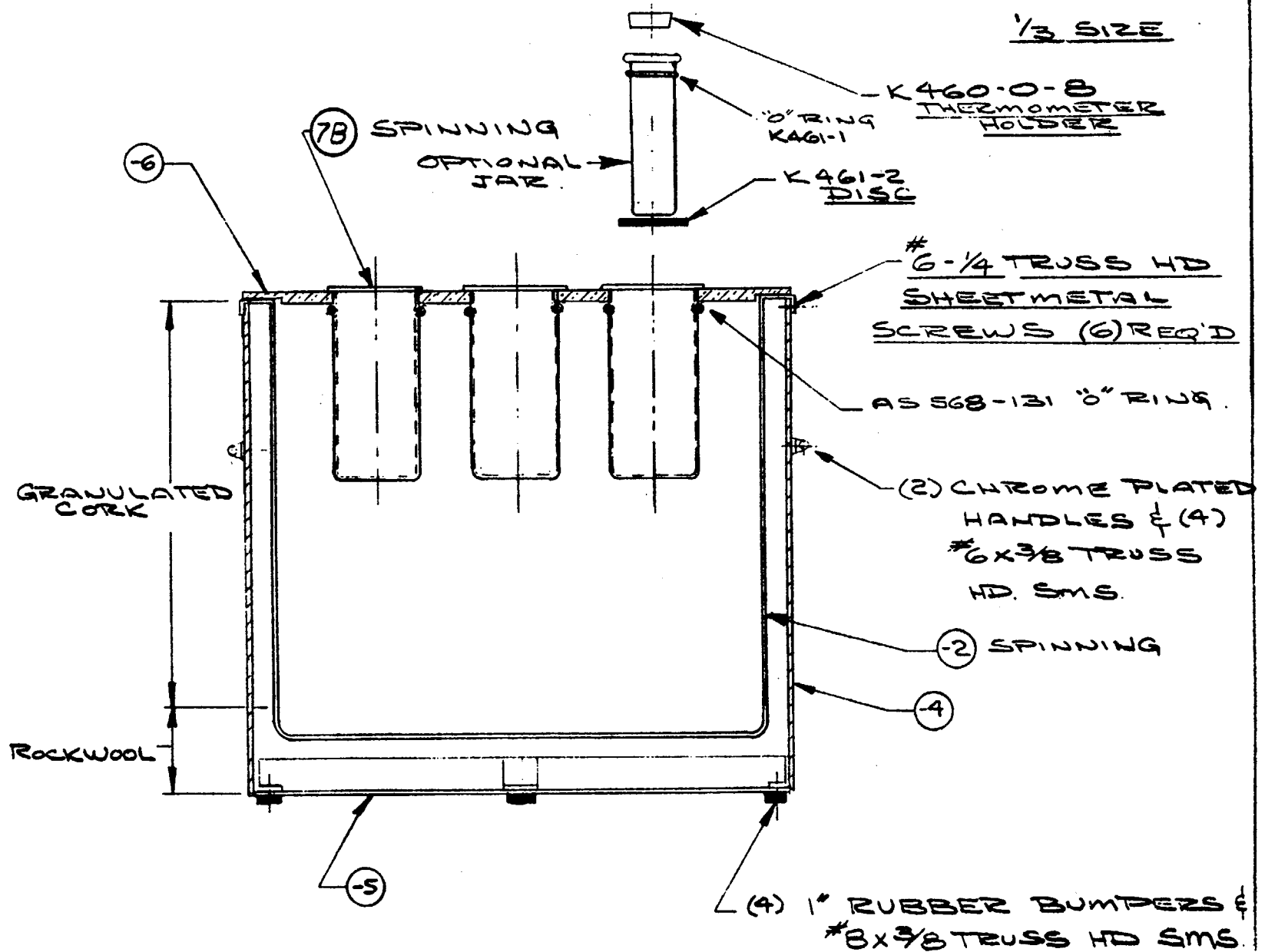

APPENDIX A

REFERENCES

A-1. **Scope.** This appendix contains all forms, pamphlets and technical manuals referenced in both the Air mobile and Semitrailer mounted Laboratories.

A-2. **Forms.**

Recommended Changes to Publications	DA Form 2028
.....	DA Form 2028-2
Quality Deficiency Report	SF 368
Equipment Inspection and Maintenance Work Sheet	DA Form 2404
Hand Receipts	DA Form 2062

A-3. **Field Manuals.**

Petroleum Testing Facilities:	
Laboratories and Kits	FM 10-72
Inspecting and Testing Petroleum Products	FM 10-70
ASTM Test Method Supplement to	FM 10-92C1/C2

A-4. **Technical Manuals.**

Atlas-Copco Compressor	TM 10-4310-392-13&P
Alcor Jet Fuel Thermal Oxidation Tester Operating and Maintenance Manual	TM 10-6635-210-13&P
Bacharach Gas Alarm and Calibration Data	TM 10-6665-29;7-13&P
Brother Portable Typewriter	TM 10-7430-218-13&P
Chemtrix Field Ph Meter	TM 10-6630-237-13&P
Elkay Manufacturing 30 GPH Cooler	TM 10-4130-240-13&P
Emcee Micro-Separometer	TM 10-6640-222-13&P
Foxboro Pressure Recording Gauge	TM 10-6685-365-13&P
Gammon Aqua Glo Water Detector	TM 10-6640-221-13&P
Gammon Mini Monitor Fuel Sampling Kit	TM 10-6630-230-13&P
Jelrus Burn-Out Furnace	TM 10-640-231-13&P
Koehler Cleveland Open Tester	TM 10-6630-236-13&P
Koehler Cloud and Pour Point Chamber	TM 10-6630-238-13&P
Koehler Copper Strip Corrosion Bomb Bath	TM 10-6640-220-13&P
Koehler Distillation Apparatus	TM 10-630-233-13&P
Koehler Dropping Point Apparatus	TM 10-6635-211-13&P
Koehler Electric Pensky-Martins Tester	TM 10-6630-231-13&P
Koehler Foaming Characteristics Determination Apparatus	TM 10-640-228-13&P
Koehler Kinematic Viscosity Bath	TM 10-6630-239-13&P
Koehler Tag Closed Cup Flash Tester	TM 10-6630-235-13&P
Lab-Line Explosion Proof Refrigerator	TM 10-6640-219-13&P
Lily Freezer	TM 10-6640-234-13&P
Millipore OM 39 Filter Holder	TM 10-6640-225-13&P
Millipore Vacuum Pump	TM 10-6640-217-13&P
Ohaus Harvard Trip Balance	TM 10-6670-278-13&P
Precision Gas-Oil Distillation Test Equipment	TM 10-6630-219-13&P
Precision General Purpose Water Bath	TM 106640-229-13&P

Precision High Temperature Bronze Block Gum Bath	TM 10-6630-234-13&P
Precision General Purpose Ovens	TM 10-6640-218-13&P
Precision Heater Instruction Manual and Parts List	TM 10-6640-223-13&P
Precision Oxidation Stability Bath	TM 10-6640-232-13&P
Precision Pensky-Martens Flash Testers	TM 10-6630-231-13&P
Precision Reid Vapor Pressure Bath	TM 10-6640-226-13&P
Precision Slo-Speed Stirrer	TM 10-6640-224-13&P
Precision Universal Centrifuge	TM 10-6640-230-13&P
Precision Universal Penetrometer	TM 10-640-228-13&P
Sargent-Welch Vacuum Pump	TM 10-4310-391-13&P
Sartorius Analytical Balance	TM 10-6670-277-13&P
Scotsman Cuber	TM 10-640-227-13&P
Soltec VOM-Multimeter	TM 10-6625-3127-13&P
Teel Self-Priming Centrifugal Pump	TM 10-6640-217-13&P
Teel Submersible Pump	TM 10-4320-320-13&P
Texas Instrument TI-503011 Calculator	TM 10-7420-210-13&P

A-5. Pamphlets.

The Army Maintenance Management System (TAMMS)	DA Pam 738-750
--	----------------

A-6. Miscellaneous Publications.

The Army Integrated Publishing and Printing Program	AR 25-30
Laboratory, Airmobile, Aviation Fuel	MIL-L-52733A(ME)
Apparatus, Instruments, Chemicals, Furniture, and Supplies for Industrial, Clinical, College and Government Laboratories	Fisher Scientific Laboratories Catalog
Petroleum-Petrochemical Testing Equipment	Precision Scientific Catalog

APPENDIX B

MAINTENANCE ALLOCATION CHART

Section I. INTRODUCTION

B-1. General.

a. This section provides a general explanation of all maintenance and repair functions authorized at various maintenance categories.

b. The Maintenance Allocation Chart (MAC) in Section II designates overall authority and responsibility for the performance of maintenance functions on the identified end item or component. The application of the maintenance functions to the end item or component will be consistent with the capacities and capabilities of the designated maintenance categories.

c. Section III lists the tools and test equipment (both special tools and common tool sets) required for each maintenance function as referenced from Section II.

d. Section IV contains supplemental instructions and explanatory notes for a particular maintenance function.

B-2. **Maintenance Functions.** Maintenance functions will be limited to and defined as follows:

a. Inspect. To determine the serviceability of an item by comparing its physical, mechanical, and/or electrical characteristics with established standards through examination (e.g., by sight, sound, or feel).

b. Test. To verify serviceability by measuring the mechanical, pneumatic, hydraulic, or electrical characteristics of an item and comparing those characteristics with prescribed standards.

c. Service. Operations required periodically to keep an item in proper operating condition, i.e., to clean (includes decontaminate, when required), to preserve, to drain, to paint, or to replenish fuel, lubricants, chemical fluids, or gases.

d. Adjust. To maintain or regulate, within prescribed limits, by bringing into proper or exact position, or by setting the operating characteristics to specified parameters.

e. Align. To adjust specified variable elements of an item to bring about optimum or desired performance.

f. Calibrate. To determine and cause corrections to be made or to be adjusted on instruments or test, measuring, and diagnostic equipments used in precision measurement. Consists of comparisons of two instruments, one of which is a certified standard of knob accuracy, to detect and adjust any discrepancy in the accuracy of the instrument being compared.

g. Remove/Install. To remove and install the same item when required to perform service or other maintenance functions. Install may be the act of emplacing, seating, or fixing into position a spare, repair part, or module (component or assembly) in a manner to allow the proper functioning of an equipment or system.

h. Replace. To remove an unserviceable item and install a serviceable counterpart in its place. "Replace" is authorized by the MAC and is shown as the third position code of the SMR code.

i. Repair. The application of maintenance services,¹ including fault location/troubleshooting,² removal/installation, and disassembly/assembly procedures³ and maintenance actions,⁴ to identify troubles and restore serviceability to an item by correcting specific damage, fault, malfunction, or failure in a part, subassembly, module (component or assembly), end item, or system.

j. Overhaul. That maintenance effort (service/action) prescribed to restore an item to a completely serviceable/operational condition as required by maintenance standards in appropriate technical publications (i.e., DMWR). Overhaul is normally the highest degree of maintenance performed by the Army. Overhaul does not normally return an item to like-new condition.

k. Rebuild. Consists of those services/actions necessary for the restoration of unserviceable equipment to a like-new condition in accordance with original manufacturing standards. Rebuild is the highest degree of materiel maintenance applied to Army equipment. The rebuild operation includes the act of returning to zero those age measurements (hours/miles, etc.) considered in classifying Army equipment/components.

B-3. Explanation Of Columns In The MAC, Section II.

a. Column 1. Group Number. Column 1 lists functional group code numbers, the purpose of which is to identify maintenance significant components, assemblies, subassemblies, and modules with the next higher assembly. End item group number shall be "00."

b. Column 2. Component/Assembly. Column 2 contains the names of components, assemblies, subassemblies, and modules for which maintenance is authorized.

c. Column 3. Maintenance Function. Column 3 lists the functions to be performed on the item listed in column 2. (For a detailed explanation of these functions, see paragraph B-2.)

d. Column 4. Maintenance Category. Column 4 specifies, by the listing of a work time figure in the appropriate subcolumn(s), the category of maintenance authorized to perform the function listed in column 3. This figure represents the active time required to perform that maintenance function at the indicated category of maintenance. If the number or complexity of the tasks within the listed maintenance function vary at different maintenance categories, appropriate work time figures will be shown for each category. The work time figure represents the average time required to restore an item (assembly, subassembly, component, module, end item, or system) to a serviceable condition under typical field operating conditions. This time includes preparation time (including any necessary disassembly/ assembly time), troubleshooting/fault location time, and quality assurance/quality control time in addition to the time required to perform the specific tasks identified for the maintenance functions authorized in the maintenance allocation chart. The symbol designations for the various maintenance categories are as follows:

-
- ¹ Services inspect, test, service, adjust, align, calibrate, and/or replace.
 - ² Fault locate/troubleshoot the process of investigating and detecting the cause of equipment malfunctioning; the act of isolating a fault within a system or unit under test (UUT).
 - ³ Disassemble/assemble encompasses the step-by-step taking apart (or breakdown) of a spare/functional group coded item to the level of its least componency identified as maintenance significant (i.e., assigned an SMR code) for the category of maintenance under consideration.
 - ⁴ Actions - welding, grinding, riveting, straightening, facing, remachining, and/or resurfacing.

- C..... Operator/Crew
- O Unit Maintenance
- F Direct Support Maintenance
- H General Support Maintenance
- D Depot Maintenance

e. Column 5. Tools and Equipment. Column 5 specifies, by code, those common tool sets (not individual tools) and special tools, TMDE, and support equipment required to perform the designated function.

f. Column 6. Remarks. This column shall, when applicable, contain a letter code, in alphabetic order, which shall be keyed to the remarks contained in section IV.

B-4. Explanation Of Columns In Tool And Test Equipment Requirements, Section III.

a. Column 1. Reference Code. The tool and test equipment reference code correlates with a code used in the MAC, section II, column 5.

b. Column 2. Maintenance Category. The lowest category of maintenance authorized to use the tool or test equipment.

c. Column 3. Nomenclature. Name or identification of the tool or test equipment.

d. Column 4. National Stock Number. The National stock number of the tool or test equipment.

e. Column 5. Tool Number. The manufacturer's part number.

B-5. Explanation Of Columns In Remarks, Section IV.

a. Column 1. Reference Code. The code recorded in column 6, Section II.

b. Column 2. Remarks. This column lists information pertinent to the maintenance function being performed as indicated in the MAC, section II.

Section II. MAINTENANCE ALLOCATION CHART

(1) GROUP NUMBER	(2) COMPONENT/ ASSEMBLY	(3) MAINTENANCE FUNCTION	(4) MAINTENANCE LEVEL					(5) TOOLS AND EQUIPMENT	(6) REMARKS
			UNIT		DS	GS	DEPOT		
			C	O	F	H	D		
01	CHAMBER, CLOUD AND POUR POINT	INSPECT REPLACE REPAIR	0.2	0.5 1.0	1.0			1	A

**Section III. TOOL AND TEST EQUIPMENT REQUIREMENTS
FOR
MAINTENANCE ALLOCATION CHART**

(1) TOOL/TEST EQUIP. REF CODE	(2) MAINTENANCE CATEGORY	(3) NOMENCLATURE	(4) NSN	(5) TOOL NUMBER
1	O, F	TOOL KIT, GENERAL AUTOMOTIVE	5180-00-177-7033	(50980) SC 5180-90 CL-N26

Section IV. REMARKS

REFERENCE CODE	REMARKS
A	REPAIR LIMITED TO REPLACEMENT OF DEFECTIVE PARTS

APPENDIX C
COMPONENTS OF END ITEM AND BASIC ISSUE ITEMS LISTS
Section I. INTRODUCTION

C-1. Scope.

This appendix lists components of end item and basic issue items for the Cloud and Pour Point Chamber to help you inventory items required for safe and efficient operation.

C-2. General.

The Components of End Item and Basic Issue Items Lists are divided into the following sections:

a. Section II. Components of End Item. This listing is for informational purposes only, and is not authority to requisition replacements. These items are part of the end item, but are removed and separately packaged for transportation or shipment. As part of the end item, these items must be with the end item whenever it is issued or transferred between property accounts. Illustrations are furnished to assist you in identifying the items.

b. Section III. Basic Issue Items. These are the minimum essential items required to place the Cloud and Pour Point Chamber in operation, to operate it, and to perform emergency repairs. Although shipped separately packaged, BII must be with the shelter during operation and whenever it is transferred between property accounts. The illustrations will assist you with hard-to-identify items. This manual is your authority to request/requisition replacement BII, based on TOE/MTOE authorization of the end item.

C-3. Explanation of Columns.

The following provides an explanation of columns found in the tabular listings:

a. Column (1) Illustration Number (Illus Number). This column indicates the number of the illustration in which the item is shown.

b. Column (2) National Stock Number. Indicates the National stock number assigned to the item and will be used for requisitioning purposes.

c. Column (3) Description. Indicates the Federal item name and, if required, a minimum description to identify and locate the item. The last line for each item indicates the CAGEC (in parentheses) followed by the part number.

d. Column (4) Unit of Measure (U/M). Indicates the measure used in performing the actual operational/maintenance function. This measure is expressed by a two-character alphabetical abbreviation (e.g., ea, in, pr).

e. Column (5) Quantity required (QTY RQR). Indicates the quantity of the item authorized to be used with/on the equipment.

Section II. COMPONENTS OF END ITEM

(1) Illus	(2) National Stock Number	(3) Description CAGEC And Part Number	(4) Usable On Code U/M	(5) Qty
		THERMOMETER, HIGH CLOUD AND POUR RANGE: -36 TO 120 °F (23035) 250-000-05F	EA	1
		THERMOMETER, HIGH CLOUD AND POUR RANGE: -38 TO 50 °F (23035) 250-000-5C	EA	1
		THERMOMETER, LOW CLOUD AND POUR RANGE: -112 TO 70 °F (23035) 250-000-6F	EA	1

**Section III. BASIC ISSUE ITEMS
NOT APPLICABLE**

APPENDIX D
ADDITIONAL AUTHORIZATION LIST

NOT APPLICABLE

D-1/(D-2 Blank)

APPENDIX E

EXPENDABLE/DURABLE SUPPLIES AND MATERIALS LIST

Section I. INTRODUCTION

E-1. Scope. This listing is for informational purposes only and is not authority to requisition the listed items. These items are authorized to you by CTA 50-970, Expendable/Durable Items (except medical, class V, repair parts, and heraldic items).

E-2. Explanation of Columns.

a. Column (1) Item Number. This number is assigned to the entry in the listing and is referenced in the narrative instructions to identify the material (e.g., Use cleaning compound, item 5, appendix C).

b. Column (2) Level. This column identifies the lowest level of maintenance that requires the listed item.

- C - Operator/Crew
- O - Unit Maintenance
- F - Direct Support Maintenance
- H - General Support Maintenance

c. Column (3) National Stock Number. This is the National stock number assigned to the item; use it to request or requisition the item.

d. Column (4) Description. Indicates the Federal item name, and, if required, a description to identify the item. The last line for each item indicates the Commercial and Government Entity Code (CAGEC) in parentheses followed by the part number.

e. Column (5) Unit of Measure (U/M). Indicates the measure used in performing the actual maintenance function. This measure is expressed by a two-character alphabetical abbreviation (e.g., EA, IN, PR). If the unit of measure differs from the unit of issue, requisition the lowest unit of issue that will satisfy your requirements.

Section II. EXPENDABLE/DURABLE SUPPLIES AND MATERIALS LIST

(1) Item Number	(2) Level	(3) National Stock Number	(4) Description	(5) U/M
			GASKET, CORK (23035) K46010	EA
			DISC, CORK (23035) K46020	EA

E-1/(E-2 Blank)

By Order of the Secretary of the Army:

CARL E. VUONO
General, United States Army
Chief of Staff

Official:

THOMAS F. SIKORA
Brigadier General, United States Army
The Adjutant General

DISTRIBUTION:

To be distributed in accordance with DA Form 12-21A, Operator, Unit and Direct Support Maintenance requirements for Laboratory, Petroleum, MTD

* U.S. GOVERNMENT PRINTING OFFICE: 1991 554-123/20085

RECOMMENDED CHANGES TO EQUIPMENT TECHNICAL PUBLICATIONS

 <div style="border: 1px solid black; border-radius: 15px; padding: 5px; display: inline-block; margin-left: 10px;"> <p style="margin: 0;"><i>THEN...JOT DOWN THE DOPE ABOUT IT ON THIS FORM. CAREFULLY TEAR IT OUT, FOLD IT AND DROP IT IN THE MAIL.</i></p> </div>		SOMETHING WRONG WITH PUBLICATION	
		FROM: (PRINT YOUR UNIT'S COMPLETE ADDRESS)	
PUBLICATION NUMBER		DATE SENT	
PUBLICATION DATE		PUBLICATION TITLE	
BE EXACT PIN-POINT WHERE IT IS			
PAGE NO.	PARA- GRAPH	FIGURE NO.	TABLE NO.
<div style="border: 1px solid black; height: 400px; margin-top: 10px;"> <p style="text-align: center; font-weight: bold; margin-top: 10px;">IN THIS SPACE, TELL WHAT IS WRONG AND WHAT SHOULD BE DONE ABOUT IT.</p> </div>			
PRINTED NAME, GRADE OR TITLE AND TELEPHONE NUMBER			SIGN HERE

The Metric System and Equivalents

Linear Measure

1 centimeter = 10 millimeters = .39 inch
 1 decimeter = 10 centimeters = 3.94 inches
 1 meter = 10 decimeters = 39.37 inches
 1 dekameter = 10 meters = 32.8 feet
 1 hectometer = 10 dekameters = 328.08 feet
 1 kilometer = 10 hectometers = 3,280.8 feet

Weights

1 centigram = 10 milligrams = .15 grain
 1 decigram = 10 centigrams = 1.54 grains
 1 gram = 10 decigrams = .035 ounce
 1 decagram = 10 grams = .35 ounce
 acres
 1 hectogram = 10 decagrams = 3.52 ounces
 1 kilogram = 10 hectograms = 2.2 pounds
 1 quintal = 100 kilograms = 220.46 pounds
 1 metric ton = 10 quintals = 1.1 short tons

Liquid Measure

1 centiliter = 10 milliliters = .34 fl. ounce
 1 deciliter = 10 centiliters = 3.38 fl. ounces
 1 liter = 10 deciliters = 33.81 fl. ounces
 1 dekaliter = 10 liters = 2.64 gallons
 1 hectoliter = 10 dekaliters = 26.42 gallons
 1 kiloliter = 10 hectoliters = 264.18 gallons

Square Measure

1 sq. centimeter = 100 sq. millimeters = .155 sq. inch
 1 sq. decimeter = 100 sq. centimeters = 15.5 sq. inches
 1 sq. meter (centare) = 100 sq. decimeters = 10.76 sq. feet
 1 sq. dekameter (are) = 100 sq. meters = 1,076.4 sq. feet
 1 sq. hectometer (hectare) = 100 sq. dekameters = 2.47
 1 sq. kilometer = 100 sq. hectometers = .386 sq. mile

Cubic Measure

1 cu. centimeter = 1000 cu. millimeters = .06 cu. inch
 1 cu. decimeter = 1000 cu. centimeters = 61.02 cu. inches
 1 cu. meter = 1000 cu. decimeters = 35.31 cu. feet

Approximate Conversion Factors

<i>To change</i>	<i>To</i>	<i>Multiply by</i>	<i>To change</i>	<i>To</i>	<i>Multiply by</i>
inches	centimeters	2.540	ounce-inches	Newton-meters	.007062
feet	meters	.305	centimeters	inches	.394
yards	meters	.914	meters	feet	3.280
miles	kilometers	1.609	meters	yards	1.094
square inches	square centimeters	6.451	kilometers	miles	.621
square feet	square meters	.093	square centimeters	square inches	.155
square yards	square meters	.836	square meters	square feet	10.764
square miles	square kilometers	2.590	square meters	square yards	1.196
acres	square hectometers	.405	square kilometers	square miles	.386
cubic feet	cubic meters	.028	square hectometers	acres	2.471
cubic yards	cubic meters	.765	cubic meters	cubic feet	35.315
fluid ounces	milliliters	29,573	cubic meters	cubic yards	1.308
pints	liters	.473	milliliters	fluid ounces	.034
quarts	liters	.946	liters	pints	2.113
gallons	liters	3.785	liters	quarts	1.057
ounces	grams	28.349	liters	gallons	.264
pounds	kilograms	.454	grams	ounces	.035
short tons	metric tons	.907	kilograms	pounds	2.205
pound-feet	Newton-meters	1.356	metric tons	short tons	1.102
pound-inches	Newton-meters	.11296			

Temperature (Exact)

°F	Fahrenheit temperature	5/9 (after subtracting 32)	Celsius temperature	°C
----	---------------------------	-------------------------------	------------------------	----

